



Complex railway bypass

Combined bypass railway and tangent road near the station of Mechelen (Belgium)

In extending the existing railway infrastructure from Brussels to Antwerp, a new double track railway is foreseen as a bypass along the railway station in the city of Mechelen. In combination with this, the station will be extended with an underground parking building. This car park will be reached by a new tangent road connection between the southern and northern part of the city, which should improve and the accessibility of the railway station and reduce the traffic in the center of Mechelen.

The road connection is situated parallel and underneath the new railway bypass for half of the project (fig. 2). This results in a combination of heavy concrete road tunnels and railway viaduct infrastructures in an urban environment. In December 2017 the project will be finished.

The tangent road tunnel

The southern tunnel entrance in the combined road and railway project consists of different cross sections (fig. 3). The end of the concrete viaduct of the bypass railway infrastructure in elevation is the start of the road tunnel for a double 2-lane road infrastructure. An optimization is achieved by bundling of

Bart De Pauw
TUC RAIL

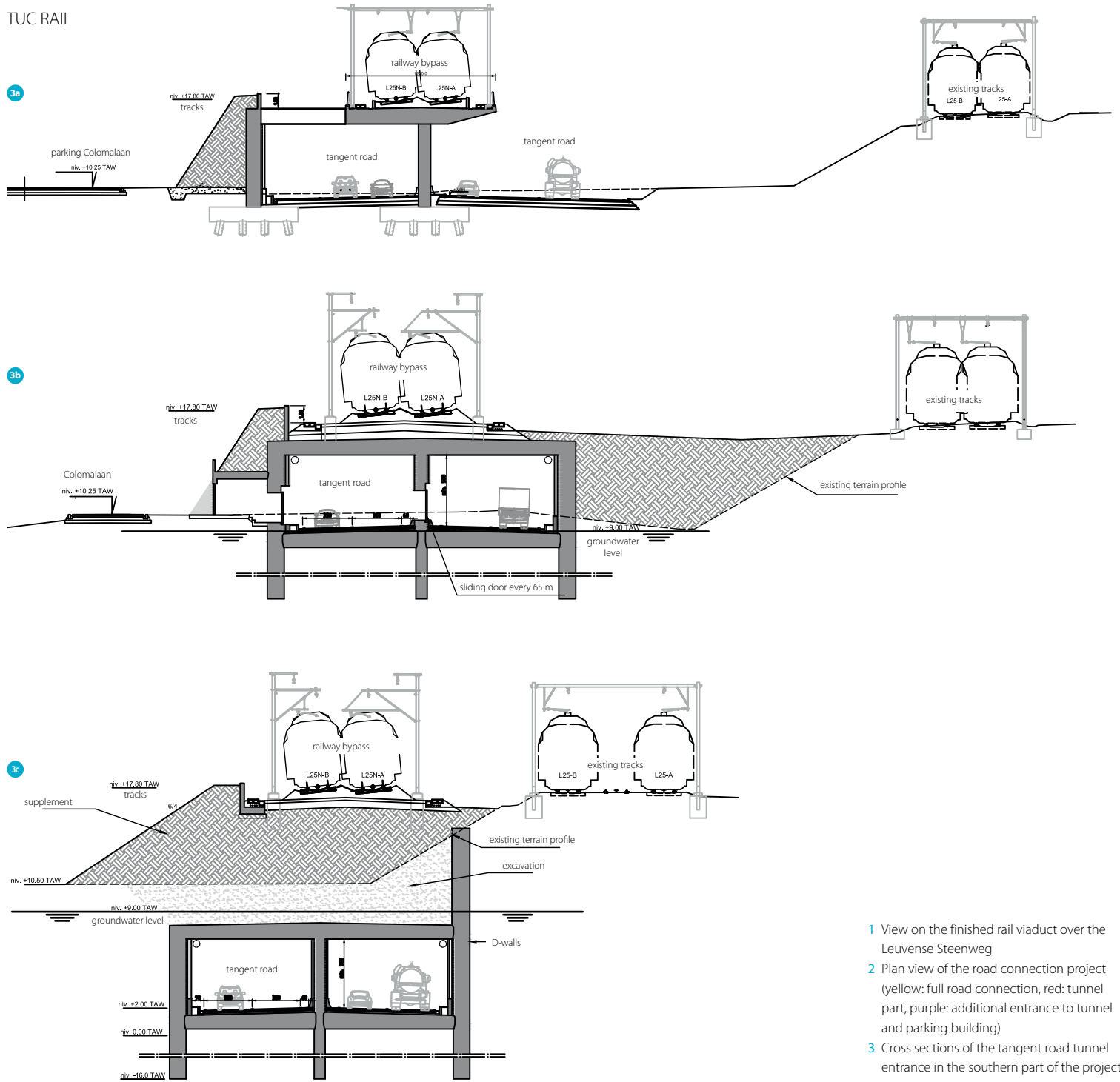

- 1 View on the finished rail viaduct over the Leuvense Steenweg
- 2 Plan view of the road connection project (yellow: full road connection, red: tunnel part, purple: additional entrance to tunnel and parking building)
- 3 Cross sections of the tangent road tunnel entrance in the southern part of the project

both infrastructures and limiting the required space. The tunnel structure consists of diaphragm walls of which the outer wall is a temporary retaining wall to the existing railway infrastructure (fig. 3c). After construction of the diaphragm walls, the tunnel deck plate will be constructed after which the tunnel can be excavated and finally the tunnel floor can be executed. In the deepest part, the tunnel structure is fully situated underneath the ground water level.

One particular structure near the tunnel entrance is the railway bridge over the Jubellaan. The railway bridge is a continuous bridge over three spans (28 m – 44 m – 28 m) with the superstructure weighing 2521 tons. The cross section consist of a

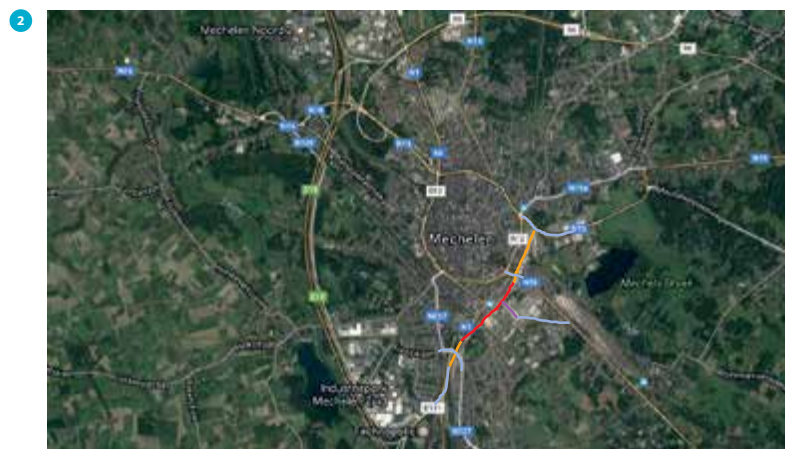



4



5

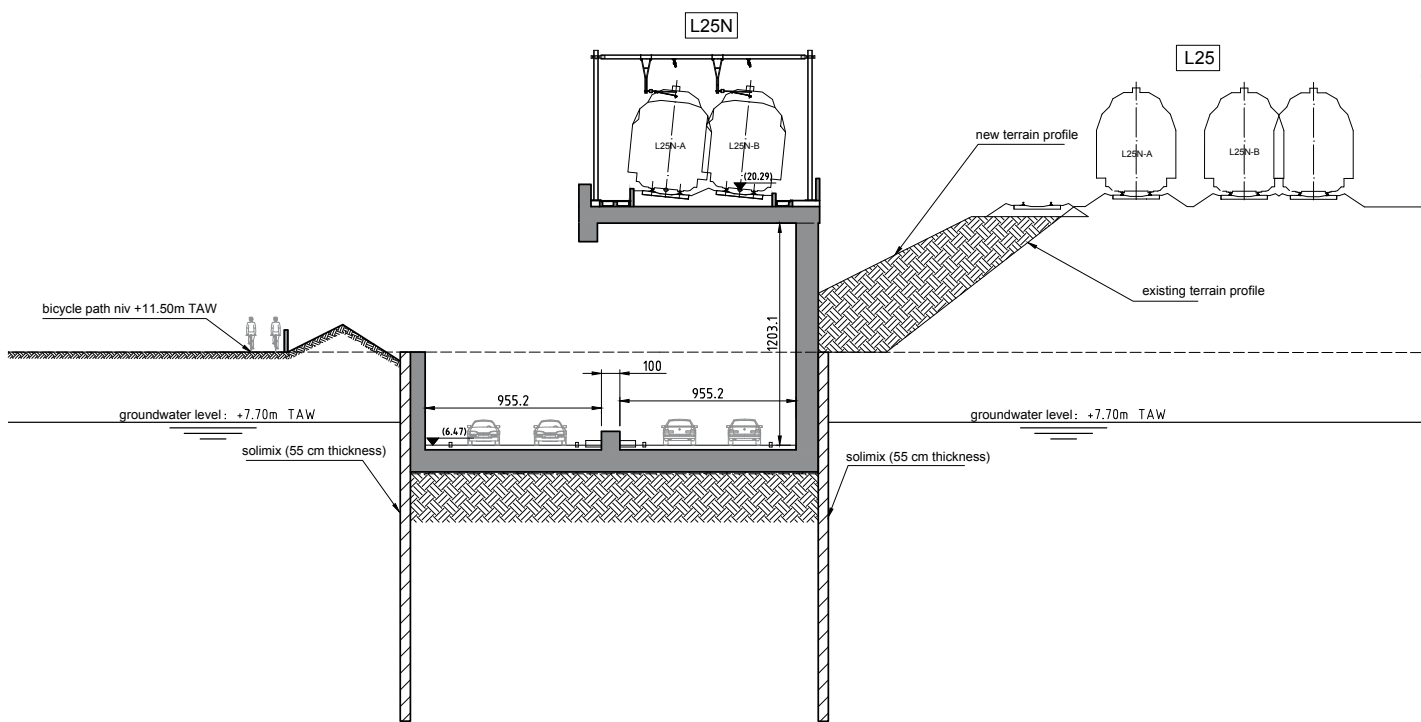

6a

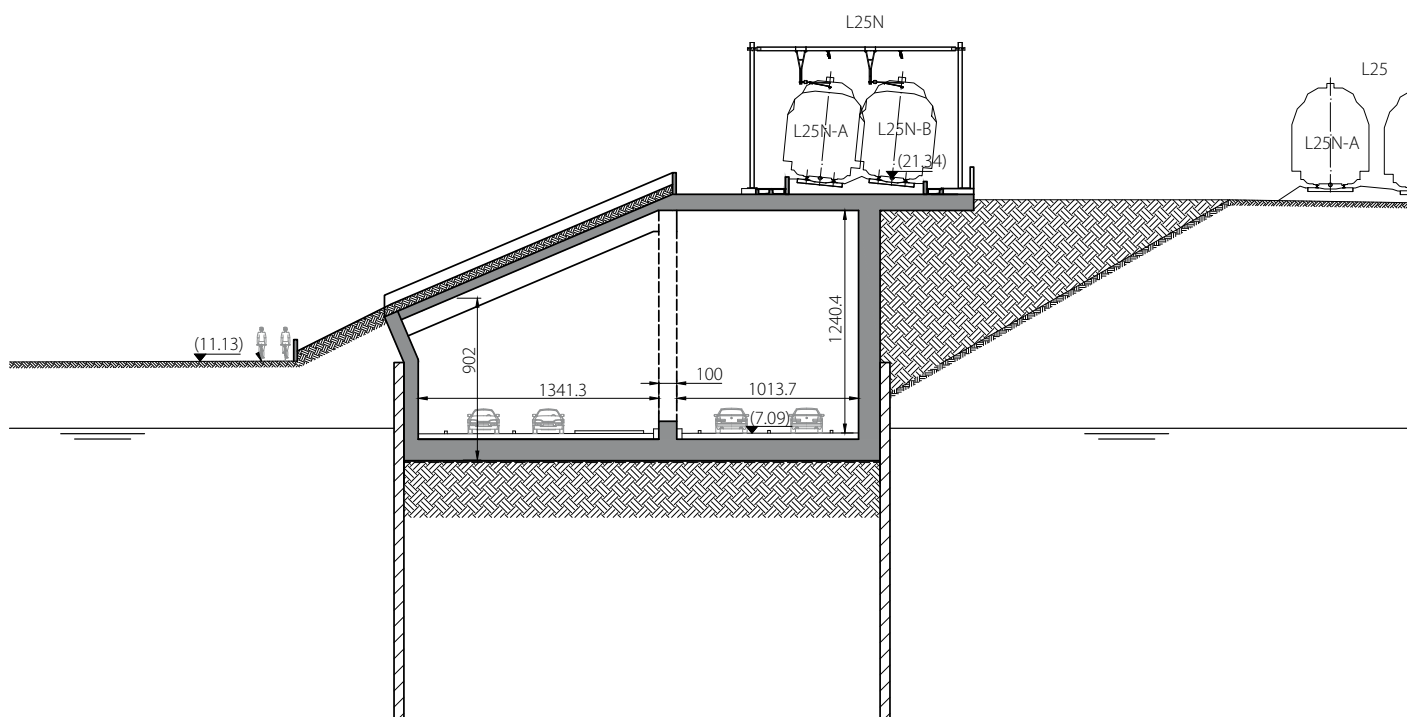

6b



7

hollow concrete cross section with post-tensioning cables in the inner ribs and external post-tensioning cables in the inner hollow parts. The cross section has variable height. Special friction tests have been performed on a test beam on site since no ATAG certification was available for the type of bonded post tensioning cables that were used. The bridge was erected some 250 m from its final position. During a weekend closure of the Jubellaan, the bridge was transported to its final position by means of a SPMT (Self Propelled Modular Transporter). Afterwards, jacking was performed in lifting and redistributing the total weight of the bridge over the pier structure and abutments (photo 4).

In the northern tunnel part of the tangent road project, road and railway alignment is split again smoothly (photo 5 and fig. 6). For architectural reasons, the roof of the tunnel opens partly and carries a green roof. When additional lanes of the tangent road structure appear towards the crossing with the existing road, the Leuvense Steenweg, the roof structure is made skew (fig. 6b). Soil mix retaining walls are made in limiting the excavation since the ground is contaminated with a historic remnant. The base of the tunnel entrance structure is situated underneath groundwater level. The rest of the tunnel structure consists of reinforced concrete. The structure is partly a retain-



8

ing structure for the existing railway infrastructure as well as a viaduct structure for the bypass railway infrastructure.

Another structure near the tunnel entrance is the railway bridge over the Leuvense Steenweg. The bridge section is an extension of only the railway section of the entrance (fig. 3a). The railway bridge is a continuous bridge over three spans (31.5 m – 33.5 m – 31.5 m) with the superstructure weighing 2750 tons. The cross section consists of a U-shaped section with outer main beams and a hollow concrete deck. Both main girders and the deck are reinforced with unbounded post-tensioning cables (photo 8). In contrast to the other railway viaduct over the Jubellaan, this bridge is cast on site, immediately at its final position (photo 1).

Skew post-tensioned concrete railway bridges

At both sides of the project to arrive to the tunnel entrances, the tangent road needs to cross the existing railway consisting of four tracks approaching the station under a skew angle of 45°. This is achieved by four similar skew post-tensioned concrete continuous slab railway bridges (photo 9a and 9b). The cross sections of the solid slab bridges with a width of 14 m are slightly curved and have side girders. The continuous slabs

- 4 View on the railway viaduct crossing the Jubellaan near the tunnel entrance
- 5 View on the northern tunnel entrance during construction
- 6 Cross sections of the tangent road tunnel entrance in the northern part of the project
- 7 View on the tangent road tunnel entrance in the northern part of the project
- 8 View on the rail viaduct over the Leuvense Steenweg under construction at the northern tunnel entrance
- 9 View and cross section of the skew post-tensioned concrete railway slab bridges

9a



9b



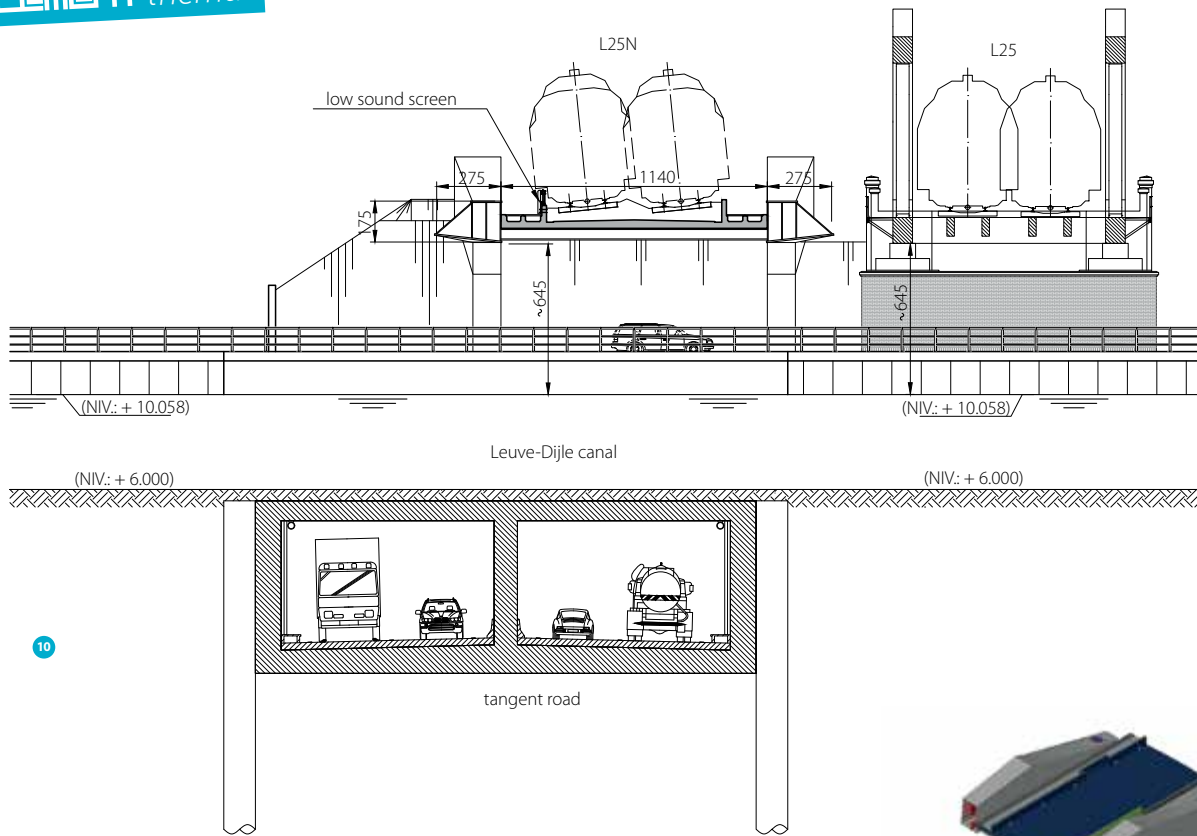

- 10 Cross section at mid span containing existing and new railway infrastructure and a new road tunnel
- 11 Artist's impression of the final design with steel portal structure
- 12 Front view and cross section of the total project with tunnel and bridge
- 13, 14 Fixations of the steel structure with post-tensioning bars

10

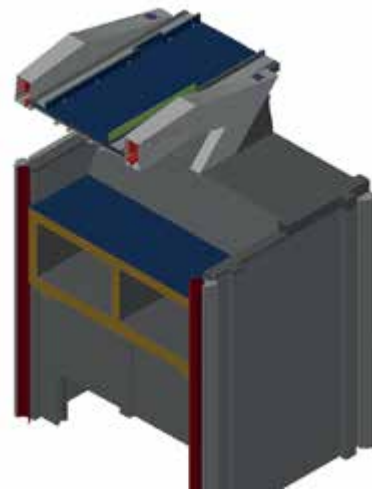

12a

have a double span of about 25 m and a total length of 50 m. The influence of the skew angle is analyzed and the post-tensioning in the edge beams has been optimized. The total railway line breaks were limited to four weekends per bridge. In the first three weekends the preparatory works are carried out in making the foundation piles and the sheet piling of the abutments and piers and in installing temporary steel bridge decks under which the abutments can be built. In the meantime, the superstructure is constructed and prestressed on a building scaffold 200 m from its final position. During the last line break, the bridge has to be transported to its final position.

The steel bridge crossing the 'Leuvense Vaart'

A particular spot in the tunnel alignment is the crossing with the 'Leuvense Vaart'. This crossing with the canal of both road and railway infrastructure is located near the existing historical steel Vierendeel bridges. The crossing of the bypass railway happens above the canal, while the tangent road infrastructure crosses the canal underneath being the deepest part of the tunnel (fig. 10). An important design criterion is keeping the full view of the historic Vierendeel bridges. A final design was developed in using an integral steel portal bridge.

The bridge consists of two lateral main girders having variable rectangular sections and is designed as an integral structure without bearings. The span is about 65 m, which is 5 m more than the arch Vierendeel bridges and has a reversed curvature near to the arch springs of the Vierendeel bridges (photo 11). The inverse curvature of the new bridge only makes sense if the abutments are fully integrated in the supporting tunnel structure underneath.

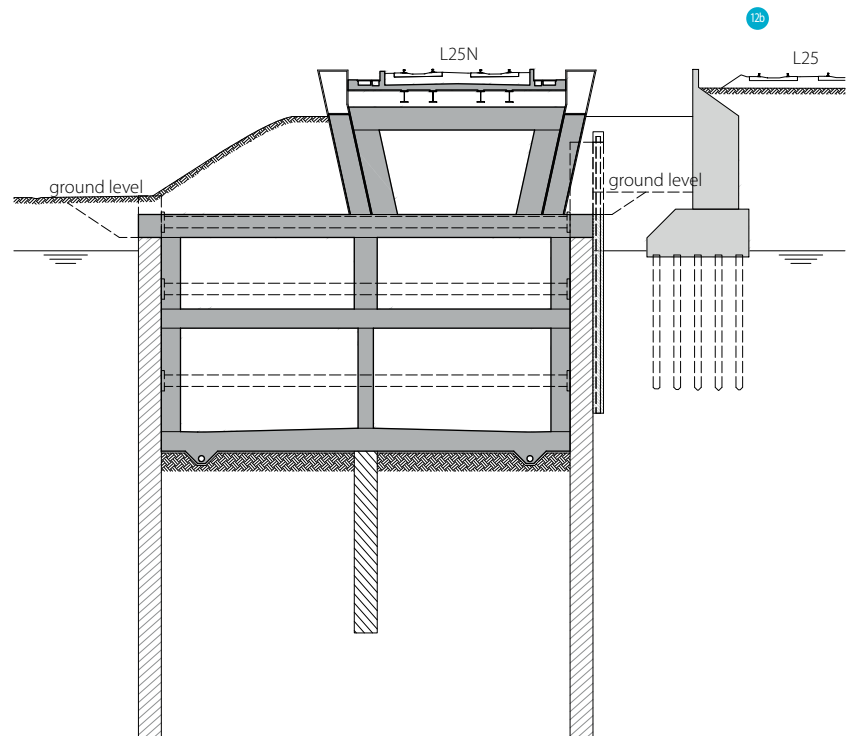

12b



11

The foundations of the new integral railway bridge consist of reinforced concrete slabs spreading the reaction forces to several diaphragm walls which are part of the tunnel structure. This is done by a complex concrete structure with internal concrete shells transferring the forces from the main box girders to the vertical walls of the tunnel (the two outer and the inner wall).

The both outer diaphragm walls are not only temporary retaining walls for construction of the tunnel, but also the final vertical deep foundations of the total structure. A particular concern in the design of the bridge is the abutment stiffness providing the clamping of the steel superstructure in the concrete foundation. Therefore, a parametric study by finite element modeling has been performed (fig. 12 [2]). The steel construction is fixed by post-tensioning bars diameter 47 mm and 75 mm as well as by steel dowels on the outer steel webs which are fading into the concrete abutments. The fixations with post-tensioning bars are simulated as fixed points at the level of horizontal steel plates (fig. 13). Photo 14 shows the preparation of the bars during execution.

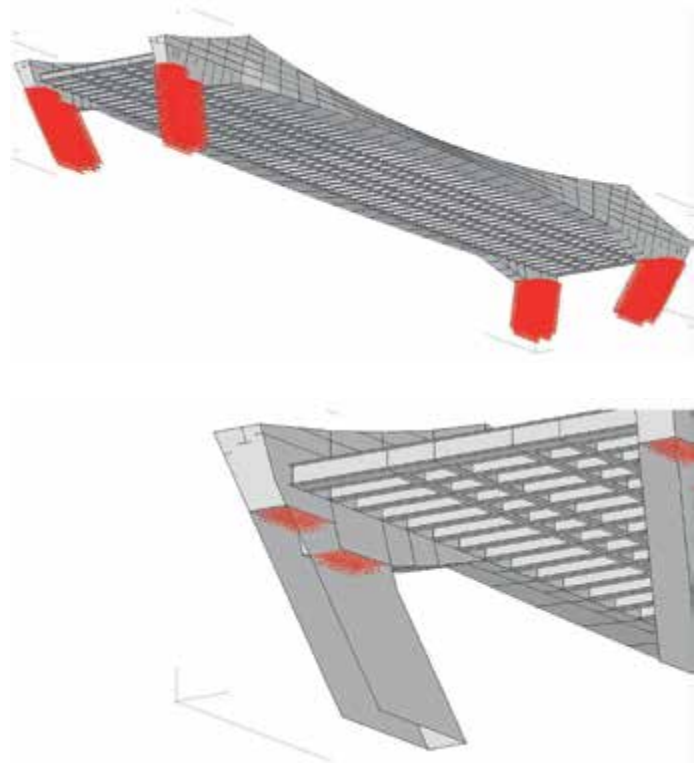

13a

13b



14

Conclusion

In completing the high speed railway network in Belgium, a new railway bypass between Brussels and Antwerp will be constructed in the city of Mechelen. This includes the extension of the existing railway station of Mechelen. The optimal bundling of both railway and tangent road makes it a complex situation. As a railway infrastructure, these structures are exceptional in the use of post tensioning concrete as well as in its design and shape. ☒

REFERENCES

- 1 Pauw, B. de, Van Bogaert, Ph. (2011). The design of an integral steel railway bridge in Mechelen (Belgium). Proc. Eurosteel 2011, Budapest, Hungary.
- 2 Pauw, B. de, (2014). The new combined road and railway infrastructure crossing the canal 'Leuvense Vaart' in bypass of the railway station of Mechelen (Belgium). Proc. Congress AFTES Lyon 2014, Lyon, France.